

**CARATTERISTICHE PRINCIPALI**
*Main features*

<b>TIPO</b> <i>Type</i>	<b>FILTRO PER GAS TECNICI E LIQUIDI</b> <i>Filter for technical gas and liquids</i>
<b>PRESSIONE DI ESERCIZIO "P.in"</b> <i>Max. Inlet pressure "P.in"</i>	<b>50 BAR</b>
<b>Attacchi</b> <i>Connections</i>	<b>1/2" GF- 3/8" GF (NPT disponibile a richiesta / NPT available on request)</b>
<b>TEMPERATURA DI ESERCIZIO</b> <i>Working temperature</i>	<b>20°+80°C</b> -4°+ 176°F
<b>PORTATA MASSIMA</b> <i>Maximum flowrate</i>	<b>~ 600 Nm³/h</b>
<b>GRADO DI FILTRAZIONE</b> <i>Filtration rate</i>	<b>50 o 5 µm</b>
<b>SCARICO DELLA CONDENZA</b> <i>Condensate drain</i>	<b>SAI - Scarico automatico / Automatic drain – Max. P.in 16bar</b> <b>SM - Scarico manuale / Manual drain – Max. P.in 30bar</b> <b>TAPPO/ CAP – Max. P.in 50bar</b>
<b>PESO</b> <i>Weight</i>	<b>2,5 kg</b> 5,5 lbs
<b>CERTIFICAZIONI</b> <i>Certifications</i>	<b>PED 2014/68/UE</b> <b>ATEX dir. 2014/34/EU</b>

**MATERIALI**
*Materials*

<b>CORPO E PARTICOLARI INTERNI</b> <i>Body and internals</i>	<b>ACCIAIO INOSSIDABILE AISI 316L</b> <i>Stainless steel AISI 316L</i>
<b>CARTUCCIA FILTRANTE</b> <i>Filter cartridge</i>	<b>AISI 316 sinterizzato</b> <i>Sintered AISI 316L</i>
<b>GUARNIZIONI</b> <i>Seals</i>	<b>FPM</b>

**SU RICHIESTA**
*On request*

<b>MATERIALI GUARNIZIONI</b> <i>Seals material</i>	<b>EPDM</b> <b>NBR</b> <b>FVMQ</b>
<b>ACCESSORI</b> <i>Accessories</i>	<b>MANOMETRO</b> <i>Pressure gauge</i> <b>STAFFA PER FISSAGGIO A MURO</b> <i>Wall mounting bracket</i>

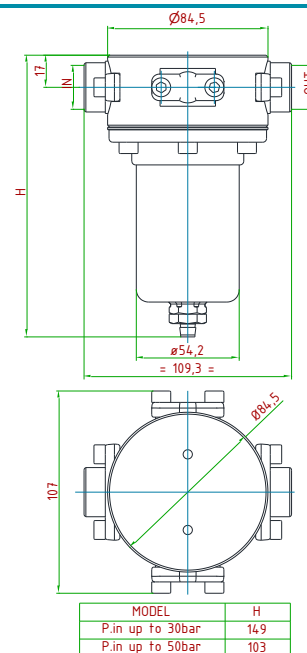
**KIT DI RICAMBIO**
*Spare parts*

<b>CODICE / order code</b>	<b>312K2#</b>
<b>CONTIENE</b> <i>The kit contains</i>	<b>O-RING, CARTUCCIA FILTRANTE, SCARICO CONDENZA (se previsto)</b> <i>O-Rings, filter cartridge, condensate drain (if required)</i>

**IDONEO PER**  
**SUITABLE FOR**
