

DEW POINT SENSOR WITH DISPLAY AND ALARM (-60°C ... +20°C)

S 201

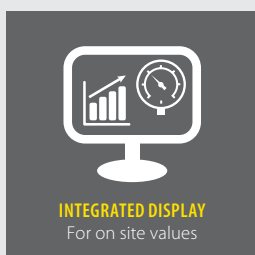

Your process under control — fast and easy dew point monitoring



S 201 FEATURES



**INTEGRATED
DISPLAY**
For on site
values



**PRECISE
MEASUREMENT**
long term stable
sensor element



**DEW
POINT**
Measures
down
to -60°C



**ALARM
RELAY**
React if your
dew point
changes

The SUTO dew point sensor S 201 provides reliable and long term stable dew point monitoring in industrial applications. The newly developed sensor features improved signal and stability in demanding industrial applications.

The measured dew point is output via a 4-20 mA signal output. The integrated display shows online measurement values and alarm status. One alarm can be programmed which will activate a relay.

S 201 features a complete dew point meter with sensor, display, keyboard and alarm.

Sensor parameters such as analogue output scaling, alarm values, units, etc, can be easily changed by using SUTO service kit. This kit is used to connect the sensor to a PC for configuration changes.

S 201 BENEFITS

- Dew point sensor for low dew point applications down to -60°C
- Long term stability
- Graphic display
- Relay output
- IP65 casing provides robust protection in rough industrial environment
- Fast response time ensures safe and reliable indication whenever dew points are out of valid ranges
- Can be installed directly into dryers through G 1/2" thread
- High accuracy of $\pm 2^\circ\text{C}$ dew point

S 201 DIMENSIONS

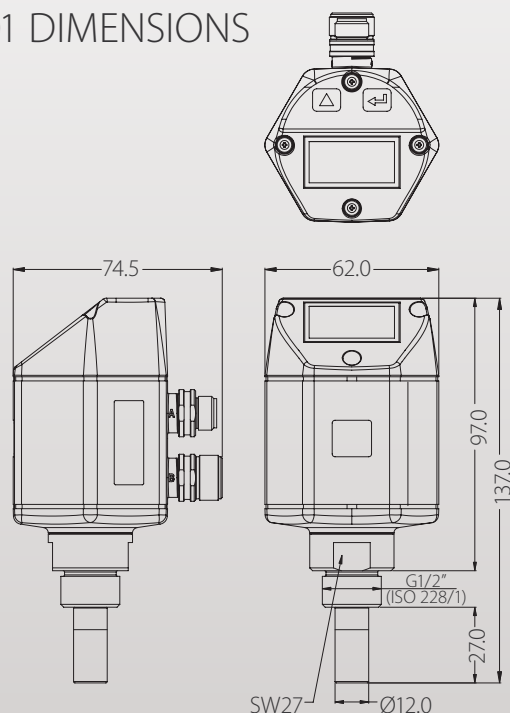

S 201 TECHNICAL DATA

General Specifications	
Measuring range	Dew point -60°C ... +20°C Temperature -30°C ... +70°C
Dew point sensor	Polymer
Temperature sensor	Pt100
Pressure sensor	N/A
Accuracy	Dew point ±2°C Temperature 0.3°C
Operating Pressure	-0.1 ... 5.0 MPa
Operating Temperature (Medium)	-30°C ... +70°C
Measured gases (Medium)	Non-corrosive gases
Response Time t90 (@ 4 l/min)	-60°C -> -20°C: 20 sec 0°C -> -60°C: 180 sec
Ambient Temperature	-20°C ... +50°C
Ambient Humidity	0 ... 90 %rH
Supply Voltage	12 ... 30 VDC
Current consumption	80 mA @ 24 VDC
Output signals	4 ... 20 mA 3-Wire Alarm Relay (NO 32 VDC / 500 mA)
Electrical connection	2 x M12, 5 poles
Process connection	G 1/2" thread (ISO 228/1) Stainless steel 1.4301 (SUS 304)
Casing material	PC + ABS
Classification	IP65
EMC	IEC 61326-1
Approval	-
Sensor protection	Sinter filter
Transport Temperature	-30°C ... +70°C
Storage Temperature	-20°C ... +50°C
Weight	226 g



Alarm adjustment at dew point sensor

S 201 ORDERING

Please use the following table to assist in placing your order with our sales staff.



Visit our website or e-mail us:
www.suto-itec.com
sales@suto-itec.com

S 201 DEW POINT SENSOR WITH DISPLAY AND ALARM (-60°C ... +20°C)	
Order No.	Description
S699 0406	S 201, dew point sensor including 2 x M12 connectors (straight type) -60°C ... +20°C, G 1/2" thread
A699 4003	High pressure option 35 MPa (350 bar)