

DEW POINT SENSOR (-50°C ... +20°C) S 212



COMPACT DESIGN
Makes it easy to fit into the application



Very fast response time — ensures safe and reliable measurements



S 212 FEATURES

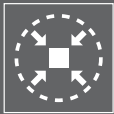

COMPACT DESIGN
Makes it easy to fit into the application



PRECISE MEASUREMENT
Long term stable results



LOW DEW POINT
Measures down to -50°C



ANALOG OUTPUT
4 ... 20 mA
3-wire

The SUTO dew point sensor S 212 provides reliable and long term stable dew point monitoring in industrial applications. The newly developed sensor features improved signal and stability in demanding industrial applications. It makes it an ideal choice for dew point measurements in desiccant dryers.

The measured dew point is output via a 4-20 mA signal output. The compact size of the sensor makes it an ideal choice for installations in tight environments. Sensor parameters such as analogue output scaling, alarm values, units, etc, can be easily changed by using SUTO service kit. This kit is used to connect the sensor to a PC for configuration changes.

S 212 BENEFITS

- Dew point sensor for low dew point applications down to -50°C
- Long term stability
- IP65 casing provides robust protection in rough industrial environment
- Fast response time ensures safe and reliable indication whenever dew points are out of valid ranges
- Can be installed directly into dryers through G 1/2" thread
- High accuracy of $\pm 2^\circ\text{C}$ dew point

S 212 DIMENSIONS

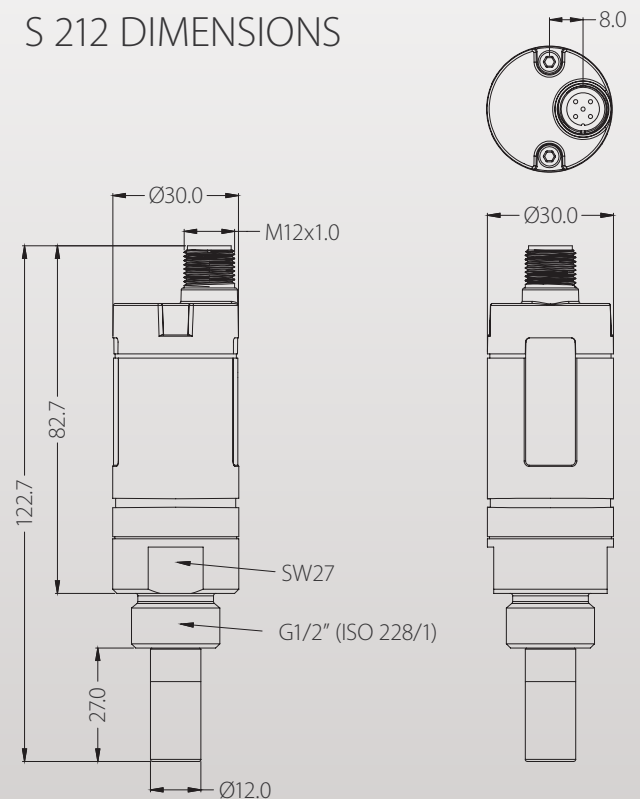

S 212 TECHNICAL DATA

General Specifications	
Measuring range	Dew point Temperature -50°C ... +20°C -30°C ... +70°C
Dew point sensor	Polymer
Temperature sensor	Pt100
Pressure sensor	N/A
Accuracy	Dew point $\pm 2^\circ\text{C}$ Temperature 0.3°C
Operating Pressure	-0.1 ... 5.0 MPa
Operating Temperature (Medium)	-30°C ... +70°C
Measured gases (Medium)	Non-corrosive gases
Response Time t90 (@ 4 l/min)	-50°C -> 0°C: 20 sec 0°C -> -50°C: 180 sec
Ambient Temperature	-20°C ... +50°C
Ambient Humidity	0 ... 100 %rH
Supply Voltage	12 ... 30 VDC
Current consumption	30 mA @ 24 VDC
Output signals	4 ... 20 mA 3-Wire
Electrical connection	M12, 5 poles
Process connection	G 1/2" thread (ISO 228/1) Stainless steel 1.4301 (SUS 304)
Casing material	Zinc alloy
Classification	IP65
EMC	IEC 61326-1
Approval	-
Sensor protection	Sinter filter
Transport Temperature	-30°C ... +70°C
Storage Temperature	-20°C ... +50°C
Weight	195 g

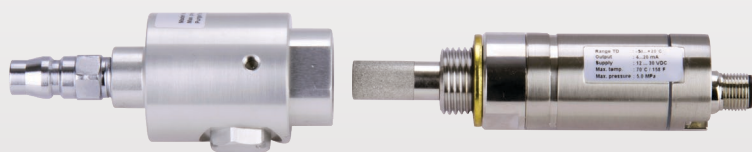

Connection of S 212 with measuring chamber to compressed air

S 212 ORDERING

Please use the following table to assist in placing your order with our sales staff.



Visit our website or e-mail us:
www.suto-itec.com
sales@suto-itec.com

S 212 DEW POINT SENSOR (-50°C ... +20°C)	
Order No.	Description
S699 0412	S 212, dew point sensor including M12 connector (straight type), -50°C ... +20°C, G ½" thread
A699 4003	High pressure option 35 MPa (350 bar)