

Pneumatic Valve - Two Way - Normally Open

Benefits & Features

- Two way normally open air operated valve with spring return
- Installation in any position
- Suitable for gaseous and liquid media
- Brass, Nickel Plated Brass or 316 Stainless Steel
- 1/4" to 1/2" BSP or NPT ports



Specification

Configuration	Pilot piston
Port Sizes	1/4" to 1/2" BSP or NPT
Orifice	see data table below
Body	Brass or 316 stainless steel (1/4" & 3/8" body only)
Media	Gaseous or liquid media. Subject to material compatibility
Pressure ranges	0-80 Bar
Min. Operating pressure	1/10 of exercise pressure with a minimum pressure of 1 Bar, max. 10bar
Seals	see order codes table

Configuration

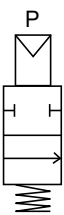

In: IN
 Out: OUT
 At Rest: IN and OUT closed
 Air in P: IN to OUT

Technical Data

Model						Port Size BSP or NPT	Orifice mm	Nominal Max. Nominal Max.	Pressure in Bar			Flow Factor KV (L/Min.)
									Differential			
	A	B	C	D	E				Min.	Max. NBR/VITON	Max. PE Seals	
M23		50				1/4"	5	80	0	30	80	6.5
M23		70				3/8"	7	80	0	30	80	12.5
M23		13				1/2"	13	80	0	30	80	40

Pneumatic Valve - Two Way - Normally Open

Weights & Dimensions

Port Size	Weight Kg.	Dimensions mm			
		A	B	C	D
1/4"	1.2	92	60	60	23
3/8"	1.6	92	60	70	23
1/2"	2.2	119	75	90	38

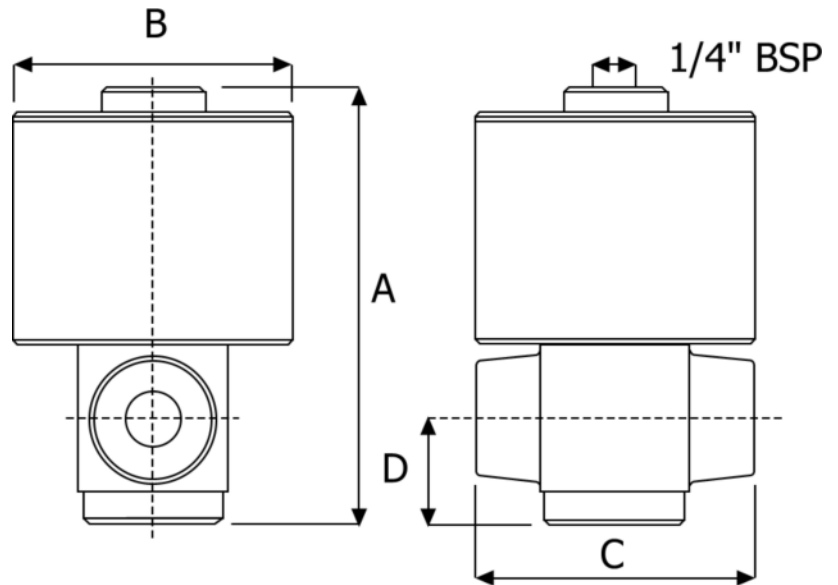

Seal Kits



Seal Material	Port Size (Brass Body)			Port Size (Stainless Steel Body)	
	1/4"	3/8"	1/2"	1/4"	3/8"
NBR	KGM/M23T50.0	KGM/M23T70.0	KGM/M23T11.0	KGM/M23I50.0	KGM/M23I70.0
VITON	KGM/M23T50.1	KGM/M23T70.1	KGM/M23T11.1	KGM/M23I50.1	KGM/M23I70.1
PE	KGM/M23T50.8	KGM/M23T70.8	KGM/M23T11.8	KGM/M23I50.8	KGM/M23I70.8

Order Codes

A	Body	B	Port	C	Seals (fluid temp. min / max)		
T	Brass	C	1/4" BSP	D	1/4" NPT	0	NBR (-10°C to + 70°C)
N	Nickel Plated Brass	E	3/8" BSP	T	3/8" NPT	1	VITON (-10°C to + 90°C)
I	316 Stainless Steel*	F	1/2" BSP	G	1/2" NPT	8	PE (-10°C to + 90°C)
* 1/4" & 3/8" bodies only							