

Solenoid Valve - Model C03 - 1/4" 3/2 Normally Closed



- Specification & Dimensions: **Pages 2-3**
- Seal kits: **Page 3**
- Installation & Maintenance Procedures: **Page 4**
- Wiring Details IP65 Solenoid Coil: **Page 5**
- Wiring Details IP67 Housing Solenoid Coil: **Page 6**
- Solenoid Coil Replacement IP67 Housing: **Pages 7-9**

Solenoid Valve - 3/2 - 1/4" - Normally Closed

Benefits & Features

- High dependency applications
- Normally closed direct acting
- Special version with UREPAN seals for liquid CO2
- Internal moving parts available as spares kit
- Brass or 316 Stainless Steel bodies
- IP65, IP67, EExd IIB, EExd IIC versions
- Ex-d IIC -60°C to +60°C ambient versions
- ATEX, EAC Ex (CU TR 012) and IECex, Ex-d approved
- Special 6W power coil, 24VDC, 0-6bar, 0.8 to 1.8mm internal orifice



Specification

Configuration	Direct Acting
Port Sizes	1/4" BSP or NPT
Orifice	0.8mm, 1.8mm, 2.5mm, 3.2mm
Kv	see table below
Body	Brass or 316 Stainless Steel
Media	Air, light oils, liquid CO2, light chemicals etc. Subject to material compatibility
Pressure ranges	See individual data tables below
Seal options	NBR -10 to +70°C VITON (-10 to +90°C) EPDM -10 to +90°C HNBR -45 to +90°C

Standard Specification

	Port Size					Port Size BSP or NPT	Orifice mm	Body Rating	Min. /Max. Operating Differential Pressures. BAR.			KV Flow Factor L/min.
	A	B	C	D	E				Min.	Normally Closed Maximum		
										AC	DC	
C03	08	C/D				1/4"	0.8	25	0	24	24	0.2
C03	18	C/D				1/4"	1.8	25	0	10	10	1.2
C03	25	C/D				1/4"	2.5	25	0	8	8	1.6
C03	32	C/D				1/4"	3.2	25	0	4	4	1.8

IP65



Manual
Override

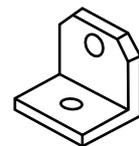

Special Model. 6W Low Power Consumption

	Port Size					Port Size BSP or NPT	Orifice mm	Body Rating	Min. /Max. Operating Differential Pressures. BAR.			KV Flow Factor L/min.
	A	B	C	D	E				Min.	Normally Closed Maximum		
										AC	DC	
C03	08	C/D			/LC	1/4"	0.8	25	0	/	6	1
C03	18	C/D			/LC	1/4"	1.8	25	0	/	6	1.2

Body Mounting Bracket 4661

IP65 IP67 EExd

Weight Kg	Dimensions mm	
	Width	Depth
0.01	18	12

Weights & Dimensions

IP65 Safe Area

IP65

Weight Kg	Dimensions mm				
	A	B	C	D	E
0.3	50	10.5	91	30	54

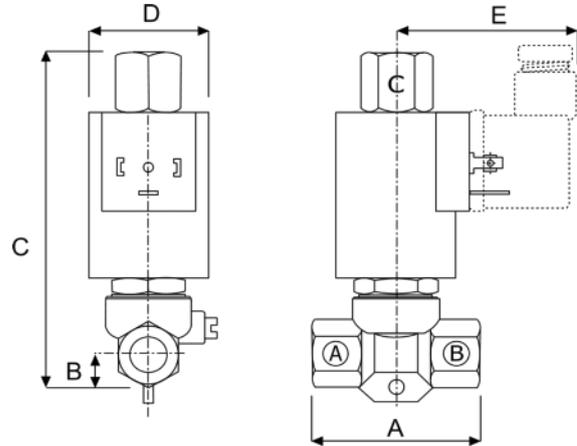

EExd Hazardous Area & IP67 Safe Area

IP67 EExd

Weight Kg	Dimensions mm				
	A	B	C	D	E
0.8	50	10.5	131	60	54

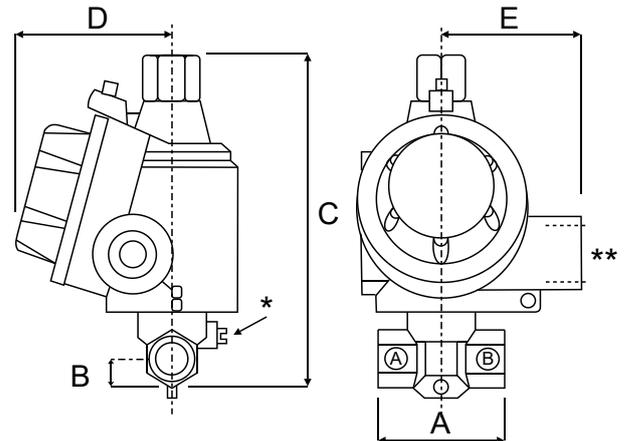

Seal Kits

IP65

IP65

Seal Material	Port Size (Brass Body)	Port Size (Stainless Steel Body)
	1/4"	1/4"
NBR	KGIP/C03T.0	KGIP/C03I.0
VITON	KGIP/C03T.1	KGIP/C03I.1
EPDM	KGIP/C03T.6	KGIP/C03I.6
HNBR	KGIP/C03T.7	KGIP/C03I.7

IP67

IP67

Seal Material	Port Size (Brass Body)	Port Size (Stainless Steel Body)
	1/4"	1/4"
NBR	KGEX/C03T.0	KGEX/C03I.0
VITON	KGEX/C03T.1	KGEX/C03I.1
EPDM	KGEX/C03T.6	KGEX/C03I.6
HNBR	KGEX/C03T.7	KGEX/C03I.7

Order Codes

A	Body	B	Port	C	Seals (fluid temp. min / max)	D	Protection	E	Options		
T	Brass	C	1/4" BSP	D	1/4" NPT	0	NBR (-10°C to +70°C)	P	IP65 Safe Area	X	Manual Override
I	316 Stainless steel					1	VITON (-10°C to +90°C)	S	IP67 Safe Area	/SG	Degreased for oxygen
						6	EPDM (-10°C to +90°C)	B	II 1/2 GD Ex-d IIB T6 (-20 to +40°C)	/AP	High pressure version
						7	HNBR (-45°C to +90°C)	C	II 1/2 GD Ex-d IIC T6 (-20 to +40°C)	/LC	* Low Power Consumption Coil
								/LT	II 1/2 GD Ex-d IIC T6 (-60 to +60°C)		* B6R100 series 24VDC solenoid coil, with 0.8mm or 1.8mm orifice. 0-6bar, power consumption 6W
								H	Ex-d c IIB IP67 IECEX		
								T	Ex-d c IIC IP67 IECEX		
								R	Ex-d IIC EAC Ex		

Solenoid Valve Installation & Maintenance

Installation Procedures & Methods

Section 1: How to install Solenoid Valves

Solenoid Valves can normally be installed and operate in any orientation. However, certain models are designed to operate in horizontal installations. Please contact Red Dragon for further information.

Installation Procedure:

Check that the Solenoid Valve is the correct product ordered for the application:

- Isolate the site electrical power supply
- Isolate the site media supply (dependant on the application)...air, water, steam etc. Leave until cool/safe.
- Insert the valve onto the pipe, ensuring that the flow direction is observed.....IN for incoming media, or an arrow stamped on the valve body.
- Ensure that the pipe connections are free from burrs or loose pipe thread tape
- Tighten all pipe joints
- Connect electrical power supply via DIN electrical socket connector, as detailed in section 1
- Ensure that DIN connector is properly connected to solenoid coil and the gasket is installed correctly
- Apply media pressure and check for leaks

Section 2: Maintenance Procedure for Solenoid Valves - IP65 Safe Area

In the unlikely event of a valve malfunction, or routine maintenance, follow these instructions:

- Isolate the site electrical power supply
- Isolate the site media supply (dependant on the application)...air, water, steam etc.
- Remove the solenoid coil by unscrewing the coil retention nut anti-clockwise
- Remove the coil tube stem by unscrewing anti-clockwise
- Carefully remove the plunger assembly (inside the coil stem)
- Check the plunger assembly for damage or worn seals
- Check the face inside the coil stem for foreign particles that could prevent correct operation
- For Pilot Diaphragm Solenoid Valves: remove the top cover housing and check the diaphragm for damage and blocked transfer port.
- Re-assemble the valve in reverse order, ensuring that all parts are cleaned and assembled correctly

Section 3: Maintenance Procedure for Solenoid Valves - IP67 Safe Area & EExd with Housing

In the unlikely event of a valve malfunction, or routine maintenance, follow these instructions:

- Isolate the site electrical power supply
- Isolate the site media supply (dependant on the application)...air, water, steam etc.
- Remove the solenoid coil by unscrewing the coil retention nut anti-clockwise
- Remove the coil tube stem by unscrewing anti-clockwise
- Carefully remove the plunger assembly (inside the coil stem)
- Check the plunger assembly for damage or worn seals
- Check the face inside the coil stem for foreign particles that could prevent correct operation
- For Pilot Diaphragm Solenoid Valves: remove the top cover housing and check the diaphragm for damage and blocked transfer port.
- Re-assemble the valve in reverse order, ensuring that all parts are cleaned and assembled correctly

Solenoid Valve Wiring - IP65 DIN Connector

IP65 DIN Connector

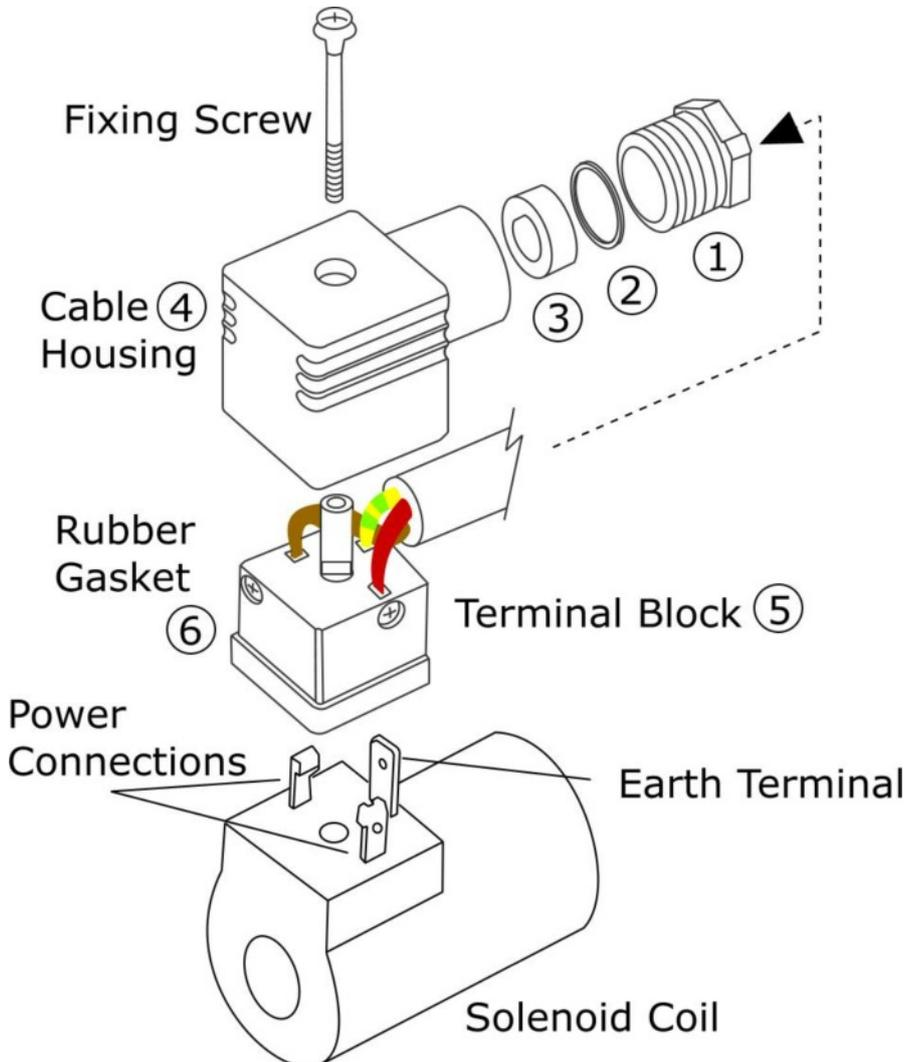

Section 1: DIN Connector Assembly

- Insert the electrical power cable through the gland assembly (1,2,3)
- Push the cable through cable housing (4)
- Connect power and earth cables to terminal block 5
- Push terminal block (5) backwards, inside cable housing (4)
- Place rubber gasket (6) on terminal block (5) front face
- Push terminal block onto solenoid coil terminals
- Push fixing screw through complete assembly
- Tighten fixing screw with small screwdriver
- Do not over tighten
- Tighten cable gland (1,2,3) by hand

Electrical Wiring - IP67 Housing

Installation Procedures & Methods

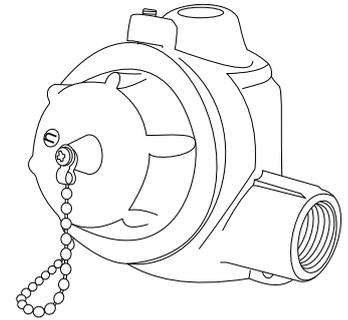

⚠ Attention: For safety purposes, always ensure that the power supply is disconnected. After de-energising, allow 15 minutes before continuing the following procedures

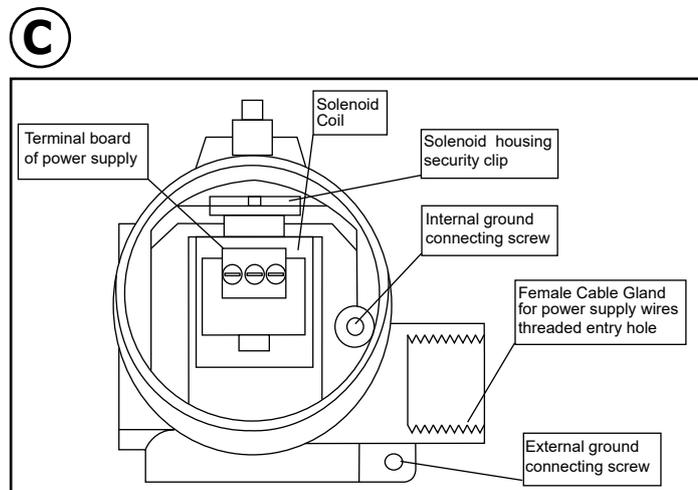
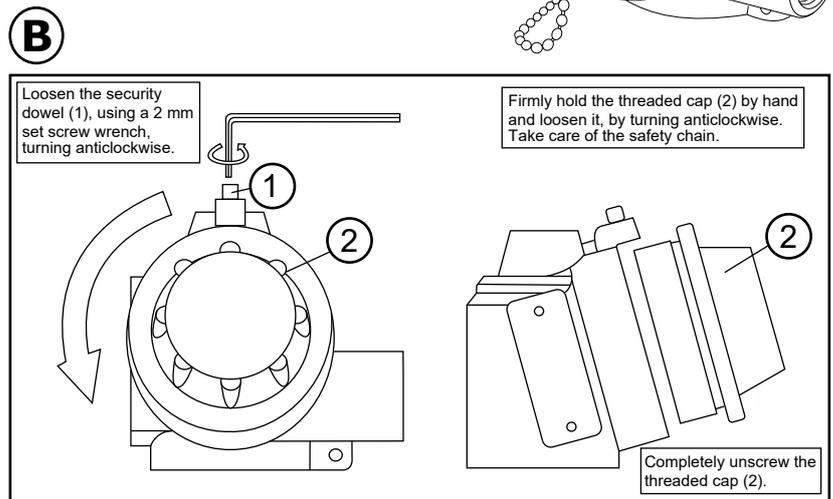
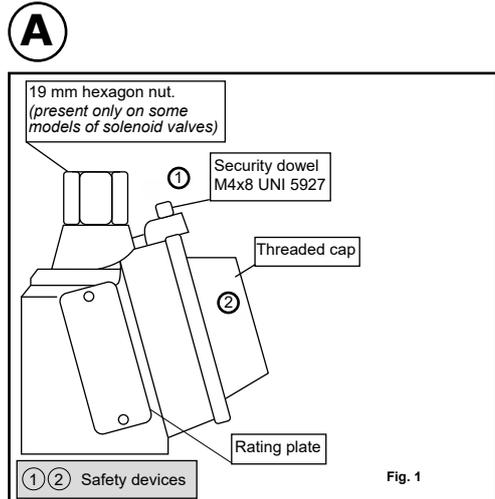

Pipe fittings used for cable entry (Cable, duct, conduit etc) are NOT supplied by the manufacturer. Installation engineers should ensure that the use of fittings are of the correct diameter and suitable to secure the tightness of the cable used. Where site conditions indicate, cable duct, conduit etc. must be ATEX approved, for a protection degree equal or greater than the protection degree indicated on the rating plate. The female thread type is indicated on the housing: M20*1.5mm or 1/2"NPT

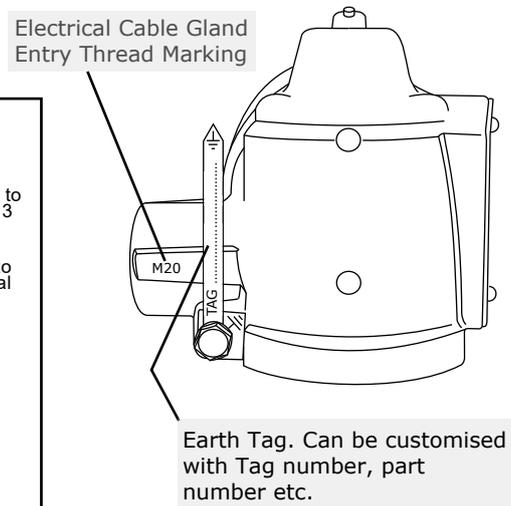
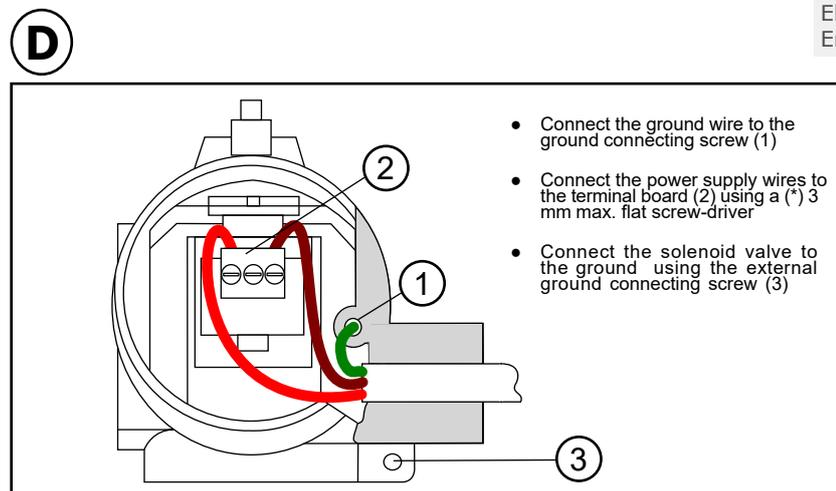



Solenoid Valve Maintenance - IP67 Housing

Solenoid Coil Removal - Operations 1-2

Tools Required



1	Solenoid housing security clip extraction tool (KM/3062)
2	Flat screwdriver (max. 3x1)
3	Special fixed core wrench (KM/2621)
4	Fixed core wrench lever pin 8mm
5	Setscrew wrench no.2
6	19mm spanner



Ensure that the power supply is switched off before commencing the following procedures

Operation 1



Loosen the security dowl using the setscrew wrench 5

Operation 2

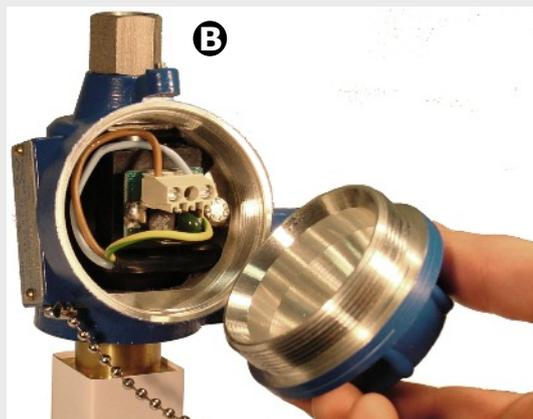
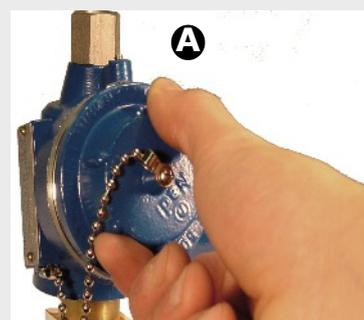

Unscrew the solenoid Housing threaded cap, By turning anti-clockwise

Solenoid Valve Maintenance - IP67 Housing

Solenoid Coil Removal - Operations 3-5

Operation 3

Insert the clip extraction tool in the solenoid housing security clip. Gently pull the clip away from the housing until it is extracted.

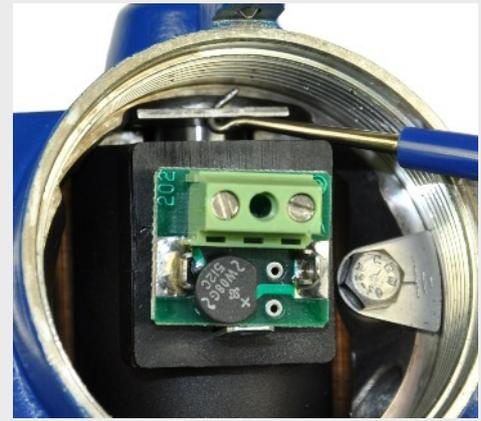
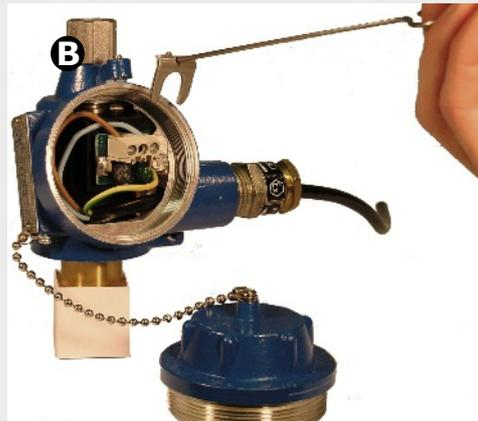
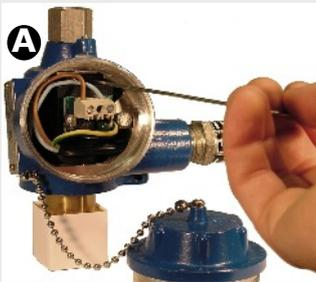

Operation 4

Loosen the terminal board screws and pull out the two power supply wires (A)

It is not necessary to unscrew the internal earth connecting wire.

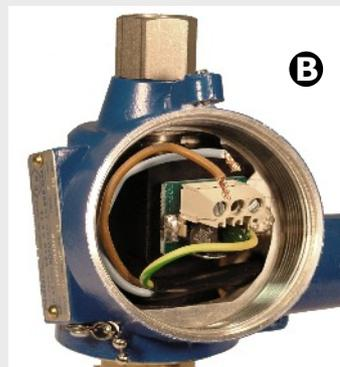
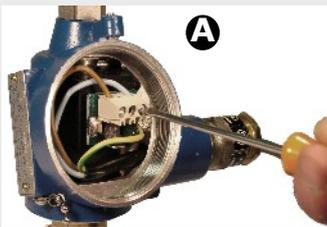

Operation 5 (if fitted)

Depending on the model, loosen the hexagonal nut with a 19mm spanner, turning anti-clockwise (A)

Once loose, unscrew the nut by Hand (B)

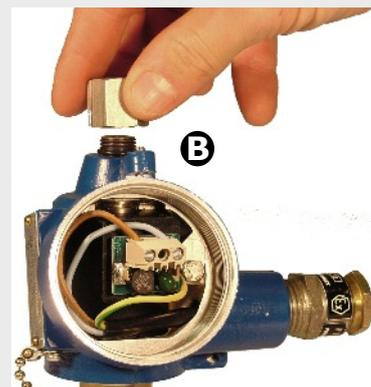
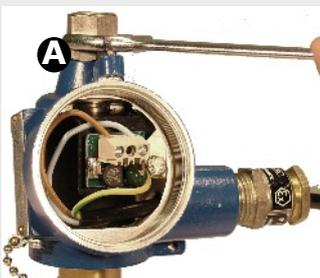



Solenoid Valve Maintenance - IP67 Housing

Solenoid Coil Removal - Operations 6-8

Operation 6

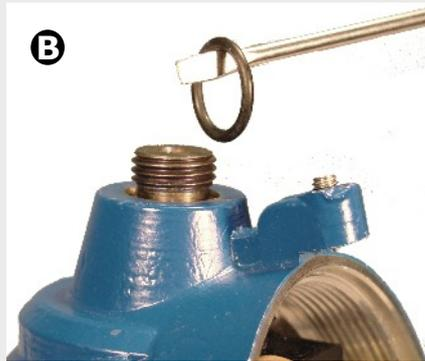
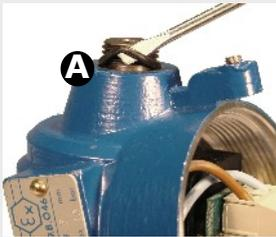

If operation 5 was necessary, carefully extract the O ring from the solenoid coil housing

Operation 7

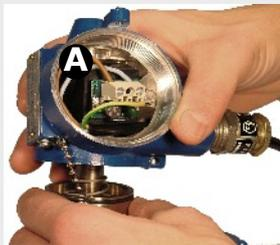

Pull up the solenoid housing until the solenoid coil is clear of the pilot assembly tube C.

Operation 8



Extract the solenoid coil from the housing, by twisting it gently leading with the top edge.