

Solenoid Valve - 3/2 - 1/4" - Manual Reset

Benefits & Features

- Three way de-energise to close
- Safety device for applications actuator protection
- Changes from rest to work condition with manual control
- Brass or 316 Stainless Steel bodies
- IP65, IP67, EExd IIB, EExd IIC versions
- Ex-d IIC -60°C to +60°C ambient versions
- ATEX, EAC Ex (CU TR 012) and IECEx, Ex-d approved
- Special model with position pin for position feedback applications

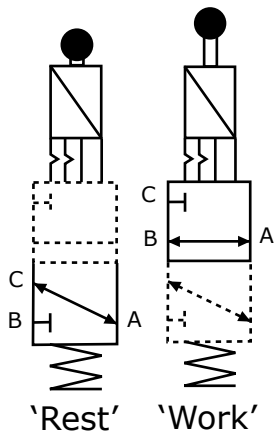

Operation

F series three way manual reset solenoid valves are normally used as safety pilot devices for single-acting actuators. The F series manual reset solenoid valves can only change from 'Reset' to 'Work' condition by operating the latching device manually.

'D' Type Operation:

Spool of the valve is manually latched to the 'Work' condition with the coil energised. De-energising the coil the spool will be unlatched and the valve will return to the 'rest' position.

Technical Data

F03	A	70	B	C	D	E	Port Size BSP or NPT	Nom Max. Bar	Orifice mm	Min./Max. Operating Differential Pres- sures.		Function	KV Flow Factor L/min.	
										Min. BAR	Maximum BAR			
											AC			DC
							1/4"	16	7.0	0	14	14	D	12



Special model with protruding pin for position feedback applications

Order Codes

A	Body	B	Port	C	Seals (fluid temp. min / max)	D	Protection	E	Options
T	Brass	C	1/4" BSP	D	1/4" NPT	0	NBR (-10°C to +70°C)	P	IP65 Safe Area
I	316 Stainless steel					1	VITON (-10°C to +90°C)	S	IP67 Safe Area
						7	HNBR (-45°C to +90°C)	B	II 1/2 GD Ex-d IIB T6 (-20 to +40°C)
								C	II 1/2 GD Ex-d IIC T6 (-20 to +40°C)
								/LT	II 1/2 GD Ex-d IIC T6 (-60 to +60°C)
								H	Ex-d c IIB IP67 IECEX
								T	Ex-d c IIC IP67 IECEX
								R	Ex-d IIC EAC Ex

Solenoid Valve - 3/2 - 1/4" - Manual Reset

Weights & Dimensions

Safe Area. IP65

Weight Kg	Dimensions mm							
	A	B	C	D	E	F	G	H
0.9	4.5	168	50	25.5	15.5	20	40	41

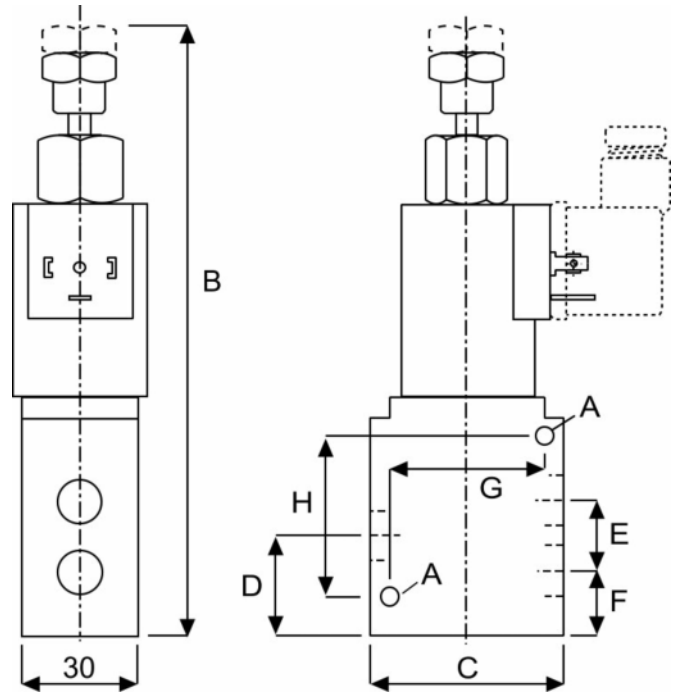

Hazardous Area & Safe Area IP67

Weight Kg	Dimensions mm							
	A	B	C	D	E	F	G	H
1.2	4.5	178	50	25.5	15.5	20	40	41

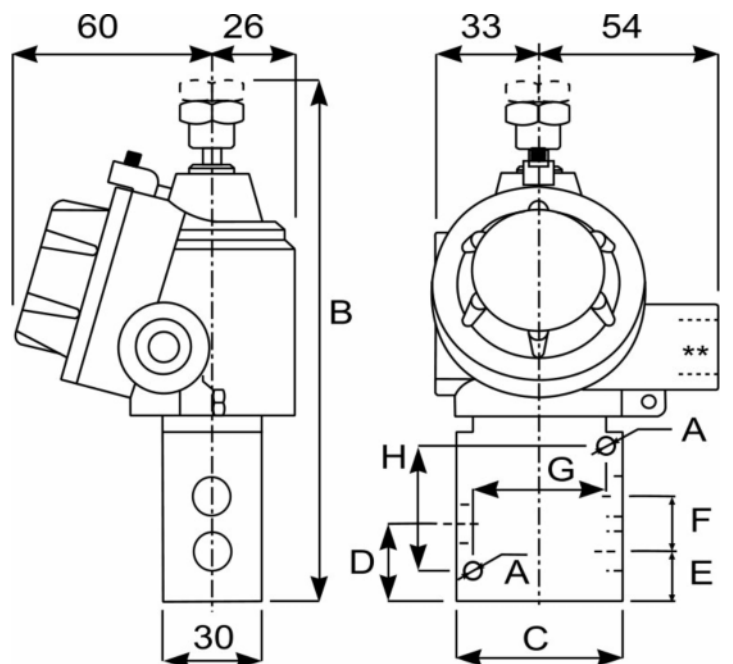

Electrical Wiring - IP67 Housing

Installation Procedures & Methods

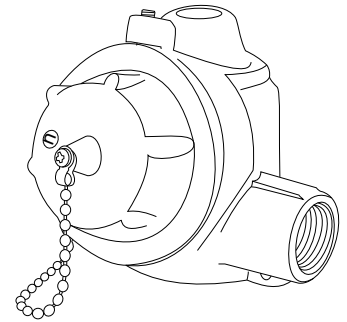

Attention: For safety purposes, always ensure that the power supply is disconnected. After de-energising, allow 15 minutes before continuing the following procedures

A

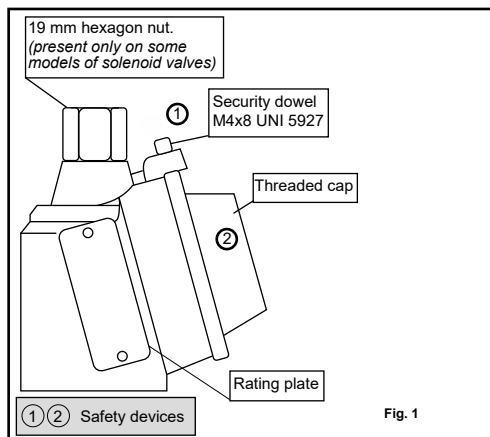

B

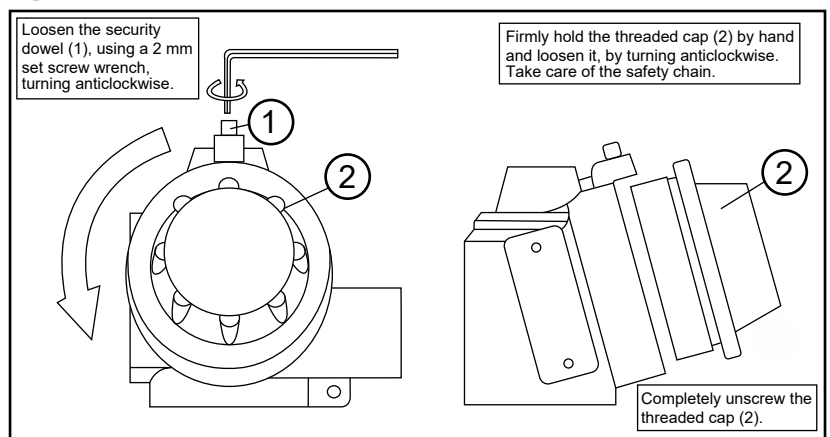

C

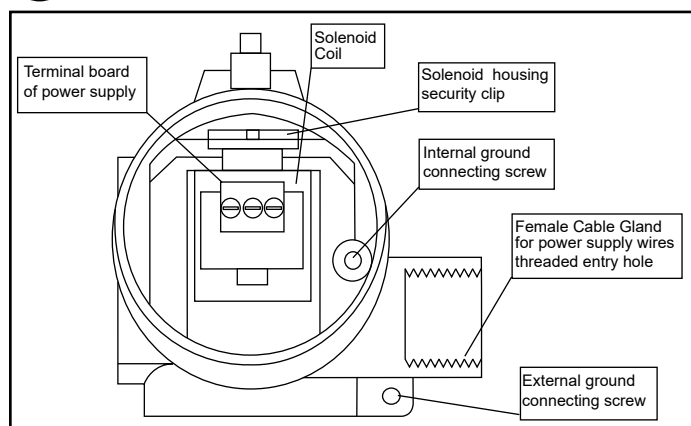

Pipe fittings used for cable entry (Cable, duct, conduit etc) are NOT supplied by the manufacturer. Installation engineers should ensure that the use of fittings are of the correct diameter and suitable to secure the tightness of the cable used. Where site conditions indicate, cable duct, conduit etc. must be ATEX approved, for a protection degree equal or greater than the protection degree indicated on the rating plate. The thread type is indicated on the housing: M20*1.5mm, 1/2"NPT or 1/2"GK

D

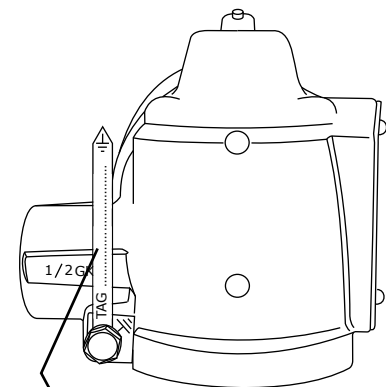
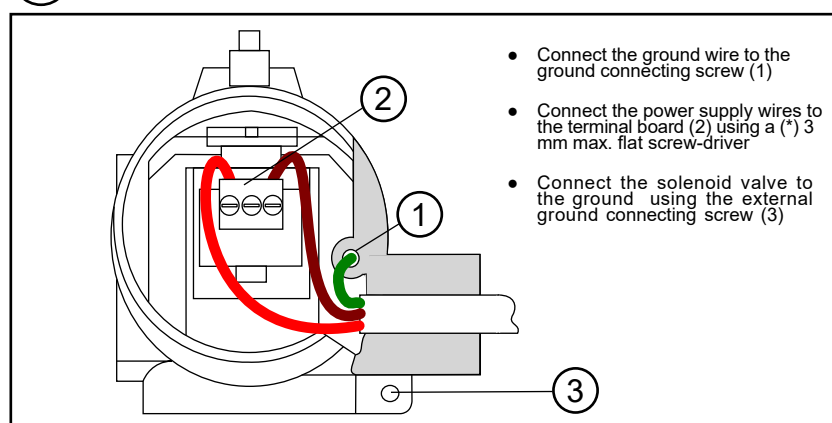

Earth Tag. Can be customised with Tag number, part number etc.

DIN electrical socket connectors to protect solenoid coil terminals and wiring.

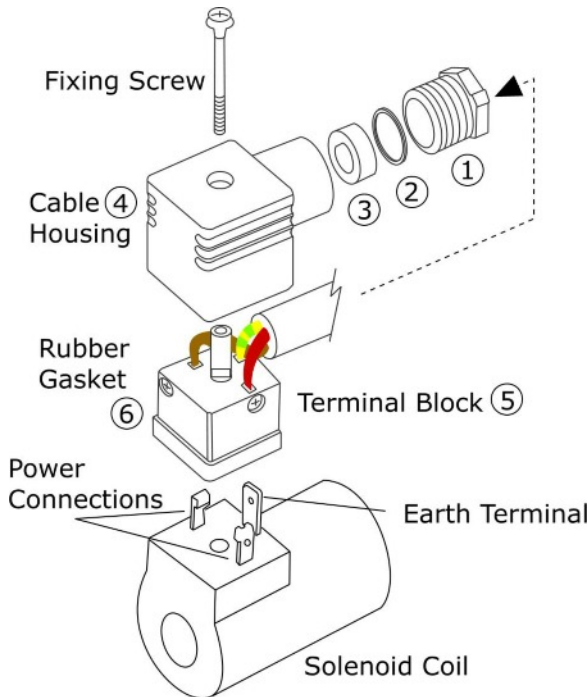

Section 1: DIN Connector Assembly

- Insert the electrical power cable through the gland assembly (1,2,3)
- Push the cable through cable housing (4)
- Connect power and earth cables to terminal block 5
- Push terminal block (5) backwards, inside cable housing (4)
- Place rubber gasket (6) on terminal block (5) front face
- Push terminal block onto solenoid coil terminals
- Push fixing screw through complete assembly
- Tighten fixing screw with small screwdriver
- Do not over tighten
- Tighten cable gland (1,2,3) by hand

Section 2: How to install Solenoid Valves

Solenoid Valves can normally be installed and operate in any orientation. However, certain models are designed to operate in horizontal installations. Please contact Red Dragon for further information.

Installation Procedure:

Check that the Solenoid Valve is the correct product ordered for the application:

- Isolate the site electrical power supply
- Isolate the site media supply (dependant on the application)...air, water, steam etc. Leave until cool/safe.
- Insert the valve onto the pipe, ensuring that the flow direction is observed....IN for incoming media, or an arrow stamped on the valve body.
- Ensure that the pipe connections are free from burrs or loose pipe thread tape
- Tighten all pipe joints
- Connect electrical power supply via DIN electrical socket connector, as detailed in section 1
- Ensure that DIN connector is properly connected to solenoid coil and the gasket is installed correctly
- Apply media pressure and check for leaks

Section 3: Maintenance Procedure for Solenoid Valves

In the unlikely event of a valve malfunction, or routine maintenance, follow these instructions:

- Isolate the site electrical power supply
- Isolate the site media supply (dependant on the application)...air, water, steam etc.
- Remove the solenoid coil by unscrewing the coil retention nut anti-clockwise
- Remove the coil tube stem by unscrewing anti-clockwise
- Carefully remove the plunger assembly (inside the coil stem)
- Check the plunger assembly for damage or worn seals
- Check the face inside the coil stem for foreign particles that could prevent correct operation
- For Pilot Diaphragm Solenoid Valves: remove the top cover housing and check the diaphragm for damage and blocked transfer port.
- Re-assemble the valve in reverse order, ensuring that all parts are cleaned and assembled correctly