

Solenoid Valve - 2/2 - Normally Closed

Benefits & Features

- High dependency applications
- Direct acting
- High pressure model up to 100 Bar (/1)
- Internal moving parts available as spares kit
- 304 stainless steel body
- IP65 solenoid coil protection

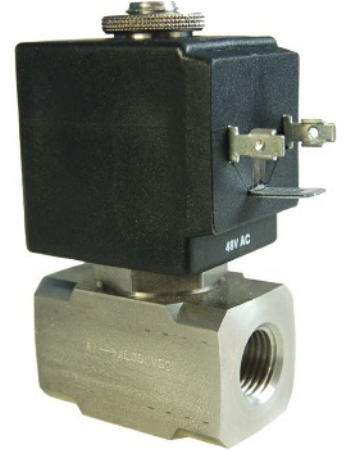

Specification

Configuration	Direct acting
Port Sizes	1/4" BSP
Orifice	see table below
Kv	see table below
Body	304 stainless steel
Media	Air, light oils, water, chemicals etc. Subject to material compatibility
Pressure ranges	See individual data tables below
Seal options	NBR VITON EPDM RULON

Technical Data

Model:						Port Size BSP	Orifice mm	Nominal Max. Bar	Min. / Max. Differential Pressures. Bar.				KV Flow Factor L/min.	
									Min.	Maximum				
A	B	C	D	E		AC	DC	AC		DC				
	L05	C	R	20	/1	1/4"	2	150	0	-	-	100	100	1.7
	L05	C		20		1/4"	2	150	0	15	15	0	0	1.7
	L05	C		35		1/4"	3.5	150	0	10	8	-	-	5.4
	L05	C	R	35	/1	1/4"	3.5	150	0	-	-	-	35	5.4
	L05	C		52		1/4"	5.2	150	0	4	1.8	-	-	7.9

Solenoid Valve - 2/2 - Normally Closed

Weight & dimensions

Weight Kg	Dimensions mm				
	A	B	C	D	E
0.4	44	13	62	75	25

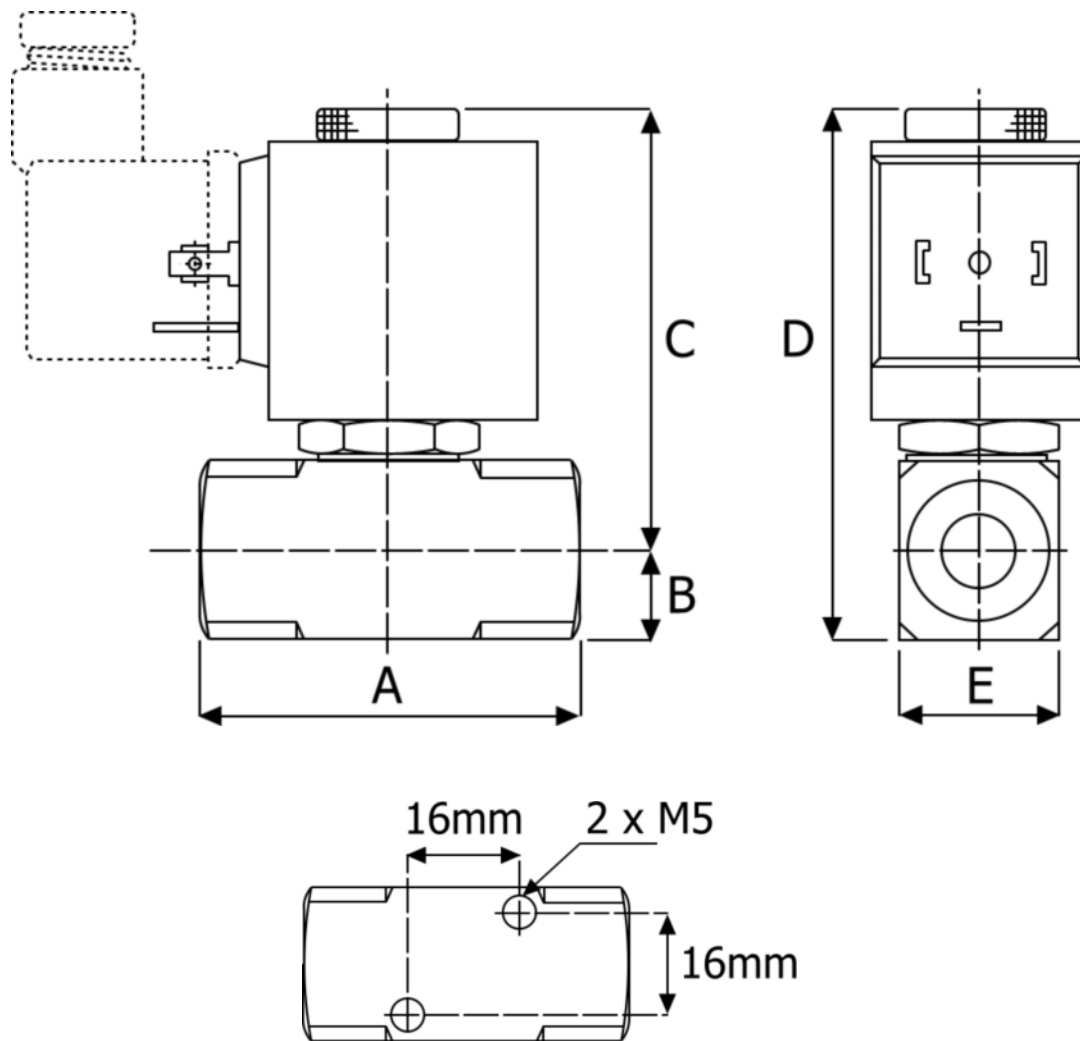

Order Codes

A	Coil Voltage	B	Port Connection	C	Seals (fluid temp min / max)	D	Body Material	E	Options
A	AC	C	1/4" BSP	B	NBR (-10°C to + 90°C)	I	304 Stainless Steel	/1	High Pressure RULON Kicker Plunger
C	DC			V	VITON (-10°C to + 130°C)				
				E	EPDM (-10°C to + 140°C)				
				R	RULON (-10°C to + 120°C)				

DIN electrical socket connectors to protect solenoid coil terminals and wiring.

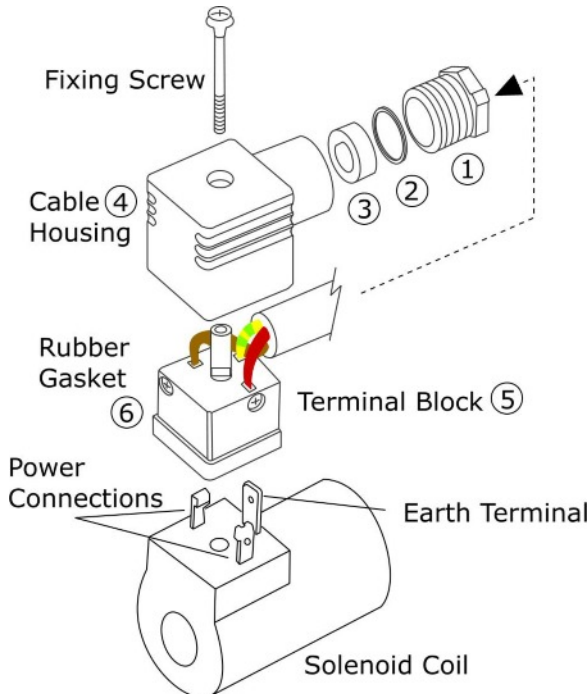

Section 1: DIN Connector Assembly

- Insert the electrical power cable through the gland assembly (1,2,3)
- Push the cable through cable housing (4)
- Connect power and earth cables to terminal block 5
- Push terminal block (5) backwards, inside cable housing (4)
- Place rubber gasket (6) on terminal block (5) front face
- Push terminal block onto solenoid coil terminals
- Push fixing screw through complete assembly
- Tighten fixing screw with small screwdriver
- Do not over tighten
- Tighten cable gland (1,2,3) by hand

Section 2: How to install Solenoid Valves

Solenoid Valves can normally be installed and operate in any orientation. However, certain models are designed to operate in horizontal installations. Please contact Red Dragon for further information.

Installation Procedure:

Check that the Solenoid Valve is the correct product ordered for the application:

- Isolate the site electrical power supply
- Isolate the site media supply (dependant on the application)...air, water, steam etc. Leave until cool/safe.
- Insert the valve onto the pipe, ensuring that the flow direction is observed....IN for incoming media, or an arrow stamped on the valve body.
- Ensure that the pipe connections are free from burrs or loose pipe thread tape
- Tighten all pipe joints
- Connect electrical power supply via DIN electrical socket connector, as detailed in section 1
- Ensure that DIN connector is properly connected to solenoid coil and the gasket is installed correctly
- Apply media pressure and check for leaks

Section 3: Maintenance Procedure for Solenoid Valves

In the unlikely event of a valve malfunction, or routine maintenance, follow these instructions:

- Isolate the site electrical power supply
- Isolate the site media supply (dependant on the application)...air, water, steam etc.
- Remove the solenoid coil by unscrewing the coil retention nut anti-clockwise
- Remove the coil tube stem by unscrewing anti-clockwise
- Carefully remove the plunger assembly (inside the coil stem)
- Check the plunger assembly for damage or worn seals
- Check the face inside the coil stem for foreign particles that could prevent correct operation
- For Pilot Diaphragm Solenoid Valves: remove the top cover housing and check the diaphragm for damage and blocked transfer port.
- Re-assemble the valve in reverse order, ensuring that all parts are cleaned and assembled correctly