

## Solenoid Valve - 2/2 - Normally Closed

### Benefits & Features

- Water, air, high pressure fluids etc
- Media temperature: -10°C to +140°C
- Two way normally closed
- Ideal for high low pressure water tank systems
- Brass, nickel plated brass or 316 stainless steel body (1/2" & 3/4" only)
- IP65 safe area



### Specification

|                        |  |
|------------------------|--|
| <b>Configuration</b>   | Lift assisted diaphragm design                             |
| <b>Port Sizes</b>      | 3/8" to 1" BSP   |
| <b>Orifice</b>         | see table below  |
| <b>Kv</b>              | see table below  |
| <b>Body</b>            | Brass  |
| <b>Media</b>           | Air, water, liquids etc. Subject to material compatibility |
| <b>Pressure ranges</b> | see data table below                                       |
| <b>Seals</b>           | see order codes table                                      |

### Technical Data

| A | L24 | B | C | 13 | D | E | Port Size<br>BSP | Orifice<br>mm | Nominal<br>Max.<br>Bar | Min. / Max. Differential<br>Pressures. Bar. |                   |    |         | KV<br>Flow<br>Factor<br>L/Min. |     |
|---|-----|---|---|----|---|---|------------------|---------------|------------------------|---|-------------------|----|---------|--------------------------------|-----|
|   |     |   |   |    |   |   |                  |               |                        | Min.  | Maximum Pressures |    |         |                                |     |
|   |     |   |   |    |   |   |                  |               |                        |   | Coil C3           |    | Coil C4 |                                |     |
|   |     |   |   |    |   |   |                  |               |                        |   | AC                | DC | AC      |                                | DC  |
|   | L24 |   |   | 13 |   |   | 3/8"             | 12.7          | 16                     | 0   | 7                 | -  | 10      | 6                              | 35  |
|   | L24 |   |   | 13 |   |   | 1/2"             | 12.7          | 16                     | 0   | 7                 | -  | 10      | 6                              | 40  |
|   | L24 |   |   | 19 |   |   | 3/4"             | 19            | 16                     | 0   | 5                 | -  | 7       | 3                              | 87  |
|   | L24 |   |   | 25 |   |   | 1"               | 25            | 16                     | 0   | -                 | -  | 7       | 2.5                            | 140 |

## Solenoid Valve - 2/2 - Normally Closed

### Weights & Dimensions

| Port Size | Weight Kg | Dimensions mm |    |    |     |    |
|-----------|-----------|---------------|----|----|-----|----|
|           |           | A             | B  | C  | D   | E  |
| 3/8"      | 0.6       | 64            | 14 | 70 | 84  | 45 |
| 1/2"      | 0.6       | 64            | 14 | 70 | 84  | 45 |
| 3/4"      | 0.9       | 82            | 17 | 77 | 94  | 55 |
| 1"        | 1.3       | 100           | 20 | 91 | 111 | 70 |

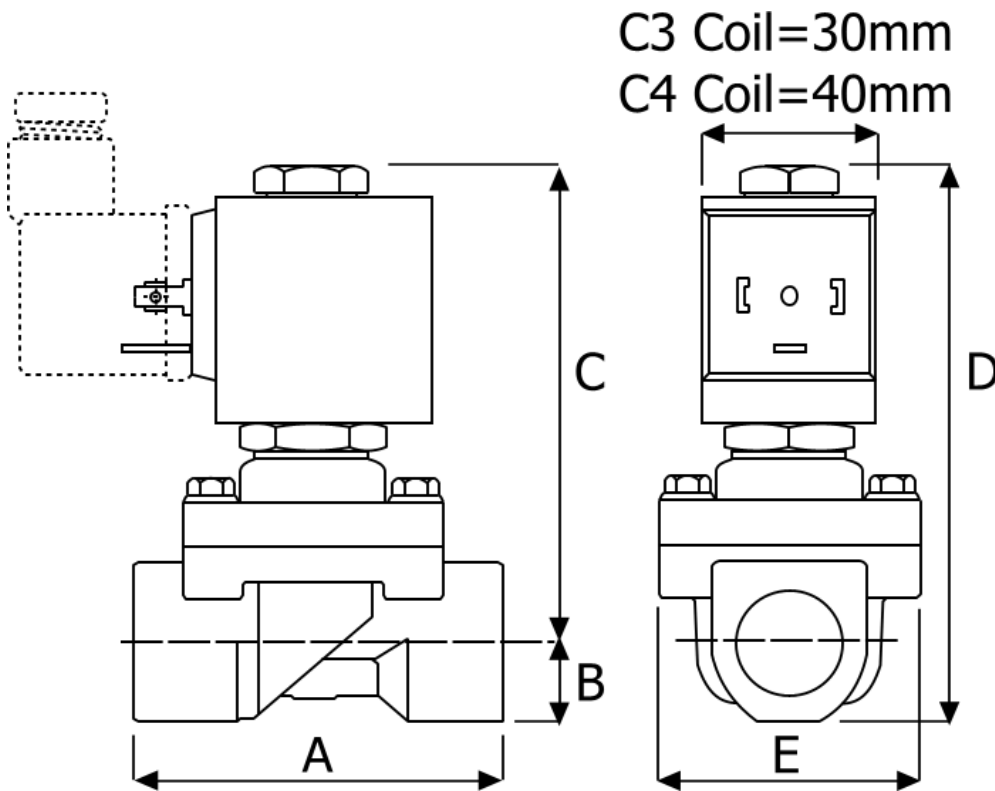

### Order Codes

| A | Coil Voltage | B | Port     | C | Seals (fluid temp. min / max) | D | Body Material           |
|---|--------------|---|----------|---|-------------------------------|---|-------------------------|
| A | AC           | D | 3/8" BSP | B | NBR (-10°C to + 90°C)         | I | 316 Stainless Steel*    |
| C | DC           | E | 1/2" BSP | V | VITON (-10°C to + 130°C)      | N | Nickel Plated Brass     |
|   |              | F | 3/4" BSP | E | EPDM (-10°C to + 140°C)       | T | Brass                   |
|   |              | G | 1" BSP   |   |                               |   | * 1/2" & 3/4" body only |

DIN electrical socket connectors to protect solenoid coil terminals and wiring.

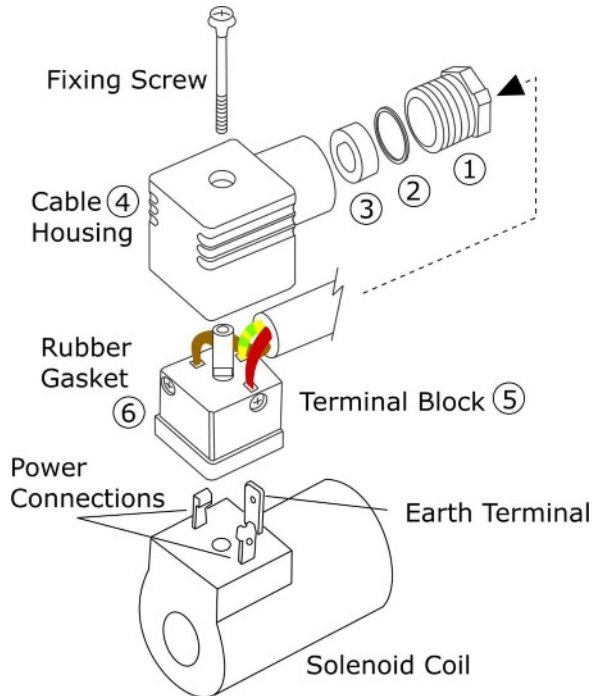

### Section 1: DIN Connector Assembly

- Insert the electrical power cable through the gland assembly (1,2,3)
- Push the cable through cable housing (4)
- Connect power and earth cables to terminal block 5
- Push terminal block (5) backwards, inside cable housing (4)
- Place rubber gasket (6) on terminal block (5) front face
- Push terminal block onto solenoid coil terminals
- Push fixing screw through complete assembly
- Tighten fixing screw with small screwdriver
- Do not over tighten
- Tighten cable gland (1,2,3) by hand

### Section 2: How to install Solenoid Valves

Solenoid Valves can normally be installed and operate in any orientation. However, certain models are designed to operate in horizontal installations. Please contact Red Dragon for further information.

#### Installation Procedure:

Check that the Solenoid Valve is the correct product ordered for the application:

- Isolate the site electrical power supply
- Isolate the site media supply (dependant on the application)...air, water, steam etc. Leave until cool/safe.
- Insert the valve onto the pipe, ensuring that the flow direction is observed.....IN for incoming media, or an arrow stamped on the valve body.
- Ensure that the pipe connections are free from burrs or loose pipe thread tape
- Tighten all pipe joints
- Connect electrical power supply via DIN electrical socket connector, as detailed in section 1
- Ensure that DIN connector is properly connected to solenoid coil and the gasket is installed correctly
- Apply media pressure and check for leaks

### Section 3: Maintenance Procedure for Solenoid Valves

In the unlikely event of a valve malfunction, or routine maintenance, follow these instructions:

- Isolate the site electrical power supply
- Isolate the site media supply (dependant on the application)...air, water, steam etc.
- Remove the solenoid coil by unscrewing the coil retention nut anti-clockwise
- Remove the coil tube stem by unscrewing anti-clockwise
- Carefully remove the plunger assembly (inside the coil stem)
- Check the plunger assembly for damage or worn seals
- Check the face inside the coil stem for foreign particles that could prevent correct operation
- For Pilot Diaphragm Solenoid Valves: remove the top cover housing and check the diaphragm for damage and blocked transfer port.
- Re-assemble the valve in reverse order, ensuring that all parts are cleaned and assembled correctly